

Public Notice Dairyland Power Cooperative

ELECTRIC POWER LINES AND GRAIN BINS DON'T MIX!

Please contact your local electric cooperative/utility if you plan to build a grain bin in the vicinity of an electric distribution line or electric transmission line.

Dairyland Power Cooperative owns and operates transmission lines in Northeastern Iowa, which provide electrical energy to local rural electric cooperatives and municipalities.

The State of Iowa requires specific clearances for electric lines around grain bins, with different standards for those filled by portable and permanent augers, conveyors and elevators.

Clearance Envelope for Grain Bins Filled by Permanently Installed Augers, Conveyors, or Elevators

Source: American National Standards Institute (ANSI) C2-2017 "National Electrical Safety Code," Rule F-234-4(a), Page 138

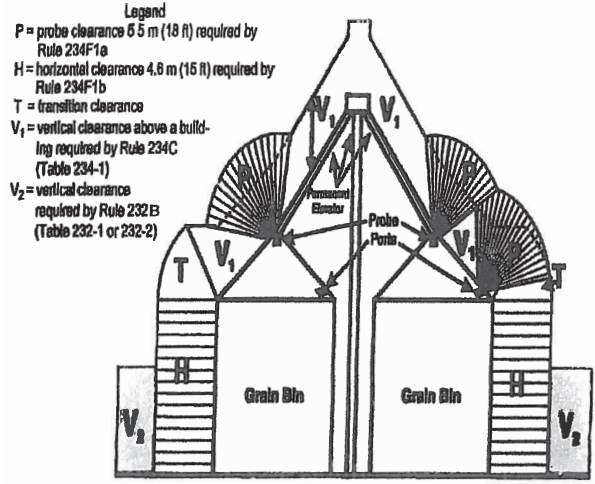

Figure 234-4(a) Clearance envelope for grain bins filled by permanently installed augers, conveyors, or elevators

Clearance Envelope for Grain Bins Filled by Portable Augers, Conveyors, or Elevators

Source: American National Standards Institute (ANSI) C2-2017 "National Electrical Safety Code," Rule F-234-4(b), Page 139

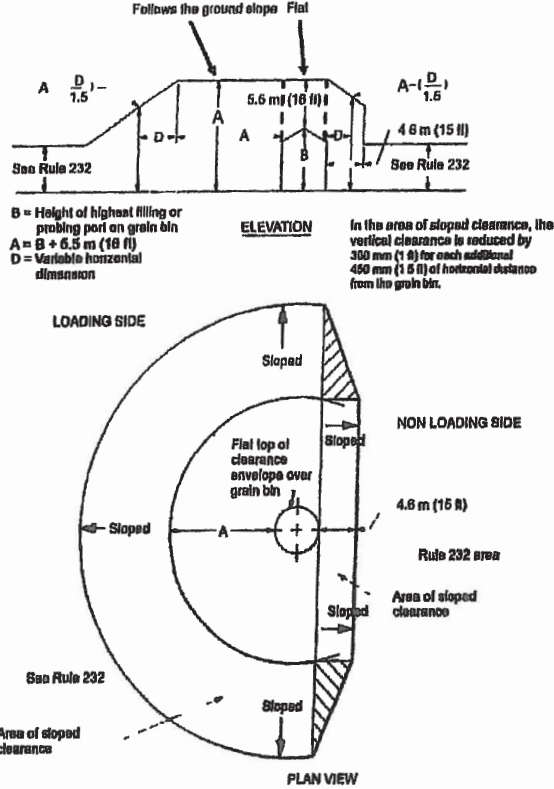

Figure 234-4(b) Clearance envelope for grain bins filled by portable augers, conveyors, or elevators

According to the Iowa Electric Safety Code found in Iowa Administrative Code Chapter 199 - 25.2(3)b., your local electric utility may refuse to provide electric service to any grain bin built near an existing electric line which does not provide the clearances required by The American National Standards Institutes (ANSI)C2-2017 "National Electrical Safety Code," Rule 234F. This Paragraph "b" shall apply only to grain bins loaded by portable augers, conveyors or elevators built after September 9, 1992, or to grain bins loaded by permanently installed augers, conveyors or elevator systems installed after December 24, 1997.

Dairyland Power Cooperative is required by the Iowa Utilities Commission to provide this annual notice to farmers, farm lenders, grain bin merchants, and city and county zoning officials.



Published in the Postville Herald on September 18, 2024.

CITY OF POSTVILLE • MINUTES-CLAIMS 09.09.2024

REGULAR MEETING OF THE CITY COUNCIL OF POSTVILLE, IOWA September 9, 2024

1. A regular meeting of the City Council of Postville, Iowa, in the Council Chambers at 147 N. Lawler St. On September 9, 2024, beginning at 7:00 p.m. with Dennis Koenig presiding.

2. On call of the roll, the following Council Members were present: Larry Moore, Devora Klein-Mahr, Laurie Moody, Mary Engstrom and Rebecca Engelhardt. Absent: None.

3. Council Member Moore made a motion to approve the agenda as posted by the Clerk. Seconded by Engelhardt. Carried 5:0.

4. Giora Bass addressed the council regarding a water leak he had at 112 N Lawler St. which resulted in high utility bill. Bass explained the leak was in the basement and the floor in the basement is dirt which was verified by the Water Operator.

5. Chris Troendle, Upper Explorer Land Regional Housing Commission, was present requesting the city committed \$12,500 per year for three years to the Housing Trust Fund.

6. The Council reviewed bids for the removal of twenty trees in the City. Bids were received from Brink Tree Service in the amount of \$16,600 and Hangartner Tree Service in the amount of \$15,000.

Seconded by Moore. Carried 5:0. 7. Council reviewed police purchase request of two solar speed signage to be placed on Lybrand and North Lawler St.

8. Council Member Engelhardt made a motion to approve the consent agenda a. Approval of the minutes of the meeting of August 12 2024. b. Departmental reports for the month of August 2024

(1) Treasurer and Clerk (2) Police (3) Swimming Pool (4) Zoning Administrator (5) Public Works (6) Library

c. Claims and Transfers for September 9, 2024. d. Annual Financial Report FY 23/24 e. Liquor License Application Sholom Raices 215 S. Lawler d/b/a New Store Class B Liquor License.

9. Council Member Moore made a motion to approve the resolution for money to pay claims. Seconded by Engelhardt. The roll was called ayes: Moore, Mahr, Moody, Engstrom and Engelhardt. Nays: None. Carried 5:0.

CASH RECEIPTS for month August 2024

Table with 2 columns: Category and Amount. Includes General, Library, Swimming Pool, RUT, HOTEL TAX, LOST, WATER, SEWER, STORM WATER, TREE/LANDSCAPE, RESOLUTION FOR THE APPROPRIATION OF MONEY, Sugar Bowl, Ice Cream Cabinet, IRS Withholdings, Casey Mielke, Kathleen Looney, Kylee Whalen, Maria Quiroz, Koby Bohr, Gage Wilker, Delila Acevedo, Jackson Moore, Dollar General Concessions, Sadie's Sweet Shop Concessions, Postville Community School Concessions, Microbac Laboratories, John's Appliance, Fridge Repair, ACCO chemicals, Black Hills Energy Utility, Alliant Energy Utility, John's Hardware, Casey Mielke Reimbursement.

BE IT RESOLVED by the City Council of the City of Postville, Iowa, that there is hereby appropriated out of any funds in the City Treasury not otherwise appropriated in payment of all bills and miscellaneous claims this day allowed: GENERAL FUND.....90,111.35 ROAD USE FUND.....16,343.96 TRUST & AGENCY FUND.....7,479.31 LOCAL OPTION SALES TAX FUND.....10,343.85 WATER FUND.....38,500.21 SEWER FUND.....26,923.95 TRANSFERS - USDA IND WW Sewer to Sewer Sinking-\$27,844. Dated at Postville, Iowa, this 9th day of September 2024.

Attest: Darcy Radloff, Clerk Dennis Koenig, Mayor CLAIMS OF SEPTEMBER 9, 2024

Table with 2 columns: Category and Amount. Includes ALLAMAKEE-CLAYT ELECTRIC SERVICE, ALLIANT ENERGY ELECTRIC SERVICE, BLACK HILLS ENERGY NATURAL GAS SERVICE, FIDELITY BANK-941 FED/FICA TAX, COMPLETE CLEANING, ELECTRIC MOTOR SHOP UNDERGROUND WIRE CHECK, HAWKINS INC., CHEMICALS, IPERS IPERS, IOWA ONE CALL, LOCATES, KEYSTONE LABORATORIES INC WATER TESTING, LIBRARY BOARD DONATION FY 25, TREASURER - STATE OF IOWA STATE TAX, CONTINENTAL RESEARCH CORP RECHARGEABLE FLASHLIGHT, STOREY KENWORTHY OFFICE SUPPLIES, VEENSTRA & KIMM SOLAR WWTF ENGINEERING, UNITED STATES POST OFFICE PERMIT FEE, DAVY LABORATORIES TESTING, ZIEGLER INC. GENERATOR REPAIR WATER PLANT, IDNR NPDES PERMIT, ALCOPRO INC. SENSOR, ERDMAN ENGINEERING ENGINEERING ZIEGLER PROJECT, ANGELA RAMOS UTILITY REFUND, MISTY HUGHES UTILITY REFUND, LISA ELLIS PAINTING, WAUKON IMPLEMENT COMPANY HYDRO LEVER TRACTOR, PAYROLL CHECKS PAYROLL CHECKS ON 08/23/2024, PAYROLL CHECKS PAYROLL CHECKS ON 09/01/2024, PAYROLL CHECKS PAYROLL CHECKS ON 09/06/2024, CLAIMS TOTAL, DENNIS KOENIG, MAYOR DARCY RADLOFF, CITY CLERK

Published in the Postville Herald on September 18, 2024.

POSTVILLE SWIMMING POOL • AUGUST 2024

Table with 2 columns: Category and Amount. Includes Dollar General concessions, Myers-Cox concessions, Column publishing, NEITEL phone, IRS Withholdings, Casey Mielke, Kathleen Looney, Kylee Whalen, Maria Quiroz, Koby Bohr, Gage Wilker, Delila Acevedo, Jackson Moore, Gage Wilker, Casey Mielke Reimbursement, ACCO chemicals, Allamaakee Co Health 2024 Inspection Fee, John's Hardware, John's Hardware Supplies, Casey Mielke Reimbursement.

POSTVILLE PUBLIC LIBRARY CHECKS AUG 2024

Table with 2 columns: Name and Amount. Includes Crystal Duffy, Carrie Sholly, Stephani Ortiz, Aura Hernandez, City of Postville, Alliant Energy Utilities, NEIT Utilities, Lynne Stone, Benda Lawn Care, Baker & Taylor Books, Mid-America publishing, DEMCO Office supplies, Elsberrnd Pest Control, Pest control.

HANGARTNER CONSTRUCTION TREE REMOVAL STORM DAMAGE, BODENSTEINER IMPLEMENT DIESEL FLUID, FISK FARM & HOME SAFETY BOOTS, VETERANS MEMORIAL HOSPITAL DRUG TESTING, ALLAMAKEE TREAS PROPERTY TAXES QUARRY HILL, SPEE-DEE SHIPPING, CLAYTON COUNTY TREASURER PROPERTY TAXES HARDIN SUB, SMITTY'S OIL & TIRE, INC. TIRE REPAIR, NORTHWEST IOWA TELEPHONE PHONE/INTERNET SERVICE, WELLMARK BLUE CROSS HEALTH INSURANCE, IROC WEBSITE DESIGN, AVESIS 3RD PART HEALTH INSURANCE, MEYER BIG IRON HYDRO HOSE/SUPPLIES, BASE INSURANCE ADMIN, ELSBERND PEST CONTROL PEST CONTROL, MIKE'S AUTO CENTER TIRE REPAIR, DEARBORN NATIONAL INSURANCE, UNITYPOINT CLINIC DRUG TESTING, NESS PUMPING LOCATE SEWER LINE, BENDA LAWN CARE LAWN MOWING, MIDWEST PATCH STREET POST BRACKETS, FARMERS UNION COOPERATIVE FUEL, ACCESS SYSTEMS COPY MACHINE AGREEMENT, TORKELSON-ELGIN OIL/ALIGNMENT CHARGER, KWIK TRIP INC. FUEL, SPARKLE WASH WASH WATER STORAGE TANK, LYNCH DALLAS, P.C. LEGAL FEES, NORTH IOWA K-9 DUAL PURPOSE K-9, VISA SUPPLIES, COLUMN SOFTWARE PBC PUBLISHING, HEATHER BENTE MILEAGE REIMBURSEMENT, T-MOBILE COUNCIL TABLETS, KLUESNER CONSTRUCTION INC GARBAGE COLLECTION, ANGELA RAMOS UTILITY REFUND, MISTY HUGHES UTILITY REFUND, LISA ELLIS PAINTING, WAUKON IMPLEMENT COMPANY HYDRO LEVER TRACTOR, PAYROLL CHECKS PAYROLL CHECKS ON 08/23/2024, PAYROLL CHECKS PAYROLL CHECKS ON 09/01/2024, PAYROLL CHECKS PAYROLL CHECKS ON 09/06/2024, CLAIMS TOTAL, DENNIS KOENIG, MAYOR DARCY RADLOFF, CITY CLERK

Published in the Postville Herald on September 18, 2024.

ALLAMAKEE COUNTY BOS • NOTICE OF PUBLIC HEARING-AMENDMENT OF CURRENT BUDGET

NOTICE OF PUBLIC HEARING - AMENDMENT OF CURRENT BUDGET Board of Supervisors of ALLAMAKEE COUNTY Fiscal Year July 1, 2024 - June 30, 2025 The Board of Supervisors of ALLAMAKEE COUNTY will conduct a public hearing for the purpose of amending the current budget for fiscal year ending June 30, 2025 Meeting Date/Time: 9/30/2024 09:40 AM Contact: Auditor Denise Beyer Phone: (563) 568-3522 Meeting Location: Board of Supervisor's room, 110 Allamaquee St, Waukon, IA 52172 There will be no increase in taxes. Any residents or taxpayers will be heard for or against the proposed amendment at the time and place specified above. A detailed statement of: additional receipts, cash balances on hand at the close of the preceding fiscal year, and proposed disbursements, both past and anticipated, will be available at the hearing. Budget amendments are subject to protest. If protest petition requirements are met, the State Appeal Board will hold a local hearing. For more information, consult https://dom.iowa.gov/local-gov-appeals.

Table with 4 columns: Line Item, Total Budget as Certified or Last Amended, Current Amendment, Total Budget After Current Amendment. Includes REVENUES & OTHER FINANCING SOURCES, EXPENDITURES & OTHER FINANCING USES, and Total Ending Fund Balance - June 30, 2025.

Explanation of Changes: Road project; to spend extra grant money received by Public Health; Conservation

Published in the Postville Herald on September 18, 2024.

